

RainSoft®

Environmental Products for the Home ...since 1953

F8C SERIES WATER TREATMENT SYSTEM

Owner's Manual



This product is manufactured in an ISO 9001:2000 certified facility.

Table of Contents

Application Limitations	3
Operational Specifications.....	3
Maintenance Requirements.....	4
Certification Information	4
Installation Instructions	5-7
System Start Up.....	8
System Settings	9-10
Troubleshooting Guide	11
Exploded View and Parts List.....	12-13
Warranty Information	14
Installer Specification Sheet	15

Congratulations! You now own the finest RainSoft Water Treatment System available to homeowners. To enjoy the maximum benefits of this system, please read the contents of this Owners Manual.

Information on Iron Removal

It is important to understand how this filter operates. The chemical used to regenerate this system is Potassium Permanganate, which is an oxidizer. When Potassium Permanganate is mixed with water, it creates a solution that is absorbed by the Greensand. As the water runs across the filter bed, the Potassium Permanganate oxidizes the iron.

The backwash rate is also very important. The iron is removed from the mineral bed during the backwash cycle. If the mineral bed is not properly expanded, the iron will foul the mineral in a short period of time.

Application Limitations

- The well pump flow rate must exceed 6 gallons per minute. Failure to properly backwash the system at a rate of 6 gallons per minute will inhibit the filter's ability to perform as designed. Frequent backwashing of the system may be required, depending on the quality of your water. See your local RainSoft Dealer for details.
- The pH range for this system is 6.9 – 8.8.
- The maximum amount of iron (Fe) for this system is 11.2 ppm.
- The maximum amount of Manganese (Mn) for this system is 2.9 ppm.

Operational Specifications

Plumbing

3/4 inch

Drain Line

1/2 inch

Water Pressure

20 psi – 120 psi (1.38 bar – 6.89 bar)

Operating Temperatures

40° F – 100° F (4.4° C – 37.8° C)

Electrical Requirements

A properly grounded alternating current supply (110 VAC 60 Hz or 230 VAC 50 Hz) is required for the operation of this system. Please check the transformer for the the correct voltage requirements.

Existing Plumbing Conditions

Plumbing should be free from lime and/or iron buildup. Piping that contains large amounts of lime and/or iron should be replaced.

Bypass Valve

The bypass valve enables you to bypass the system in situations of: emergency leaks in the equipment, service calls and/or outdoor water use.

Additional Specifications

- Do not install this system where water is microbiologically unsafe or of unknown quality without adequate disinfection before or after the system.
- This system must be installed in accordance with all applicable state and local laws and regulations.
- This system must be installed in an area not affected by extreme heat, cold or the elements. The selected installation area must be adequate for easy service of all parts.
- This system is designed to treat cold water only. The installation must be on a cold water supply.

Data Chart

Model	Tank Size	Media	Maximum Service Flow Rate	Backwash Rate	psi Drop @ Service Flow Rate	Capacity for Iron Removal
F8C 100 GP	10 x 44	1.0 cu.ft.	6.0 gpm	6.0 gpm	5.0 psi	300 gallons
F8C 150 GP	10 x 54	1.5 cu.ft.	6.0 gpm	6.0 gpm	5.0 psi	450 gallons

Maintenance Requirements

Potassium Permanganate

When the Potassium Permanganate is consumed, it must be replaced. The rate of consumption is based on the frequency of regenerations and the water temperature. For replacement Potassium Permanganate, please contact your local RainSoft Dealer.

Filter Media

The filter media will eventually become exhausted or consumed and will need to be replaced. Your RainSoft Dealer can give you specific replacement schedules based on your water usage and incoming water quality. For replacement filter media, please contact your local RainSoft Dealer.

Regeneration Valve

The regeneration valve is designed to last a lifetime, but from time to time it may be necessary to clean and lubricate the moving parts. Your water quality and the amount of regeneration necessary will affect this maintenance schedule. Your local RainSoft Dealer is knowledgeable in the different water qualities and will have the necessary parts to complete this service.

Solution Tank Float Assembly

It is recommend that the solution tank float assembly be serviced annually.

! Important Notes: Use protective gloves and eye protection when handling this chemical!

If your iron filter is not followed by a conditioner, do not use chlorine bleach in your laundry. A non-chlorine bleach will work sufficiently.

Certification Information

Water treatment devices sold to retail consumers in California, accompanied by certain health claims, must be certified by the State of California Department of Public Health. This product is not certified in the State of California for the purpose of making health claims.

Installation Instructions

1. Safety Precautions

- To prevent accident or injury, do not hoist the unit over your shoulder. Use a hand truck to transport the unit.
- Do not lay the unit on its side.
- Wear safety glasses and work gloves during the installation.

2. Test the Raw Water

- Test the raw water for iron and pH.
- If the pH is lower than 6.8, corrections must be made with a Acid Neutralizing Filter or a Chemical Feed System, using soda ash or a caustic soda solution. Contact your local RainSoft Dealer for more information.

3. Check the Well Pump Flow Rate

- With no water running in the system, open a faucet and let the water run. When the pump motor starts, note the time and close the faucet. When the pump motor stops, record the time in seconds.
- Run water into a measured container (pail with markings, gallon jug, etc.) until the pump starts. Record the number of gallons in the container.
- Divide the gallons of water in the container by the number of seconds the pump ran. This number is your gallons per second. (The number should be less than one.)
- To calculate the gallons per minute, multiply the gallons per second by 60. Repeat this procedure at least three times to obtain the average well pump flow rate.

4. Locate a Site for the System

- The installation site must have a level, smooth, and clean surface. If the location is not level, you will need to make the necessary adjustments.
- If the system is located outdoors, protect the unit from direct sunlight. Direct sunlight can damage the fiberglass and other system components. If necessary, build a box or shed.

5. Add Gravel and Manganese Greensand (F8C 150 GP Only)

- Remove the plastic cap from the tank; Cap off or plug the riser pipe to avoid pouring mineral down the riser pipe.
- Pour the gravel into the tank. Shake the tank back and forth to help level the gravel.
- Pour the Manganese Greensand into the tank.

! Important Note: The well pump flow rate must exceed the recommended backwash flow rate of 6 gallons per minute for the system to clean effectively. Failure to properly backwash the system will result in premature system failure.

Example: The water measurement is 6.5 gallons and the pump time is 40 seconds.
 $6.5 \text{ gallons} / 40 \text{ seconds} = 0.1625 \text{ gallons per second}$
 $0.1625 \text{ gallons per second} \times 60 \text{ seconds} = 9.75 \text{ gallons per minute}$
For this example, the well pump flow rate is 9.75 gallons per minute.

! Important Note: The system must be level to ensure a proper backwash. Systems that are not installed on a level surface may channel and shorten the mineral life.

! Important Note: The system can only be installed outdoors in climates that do not reach freezing levels.

6. Install the Valve Head

- Remove the cap plug from the tank.
- Lubricate the riser pipe o-ring and tank o-ring with the proper silicone lubricant.
- Align the control valve with the riser pipe and slowly lower the control valve onto the riser pipe, using a twisting motion.
- Align the control valve with the tank. Push down on the control valve and continue to turn it clockwise until the valve o-ring seals against the tank.

! Important Note: Do not over-tighten the valve to the tank.

7. Turn Off the Water and Drain the Plumbing

- Turn off the water at the meter or the pressure tank.
- Drain all the pipes. Do not sweat pipes with water in them; steam will damage the plastic parts in the valve.
- To drain the plumbing system, open all the faucets in the house and flush the toilets. The water will drain out of the lowest faucet or outlet.

! Helpful Tip: This procedure will allow air to enter the plumbing system.

8. Bypass the Outside Faucets

- Install plumbing pipes to bypass the outside faucets. If the plumbing is not accessible, provide an untreated hose bib on the inlet pipe.

9. Create the Plumbing Connection

- Once the plumbing is complete, connect the yoke to the bypass valve (see figure 1).

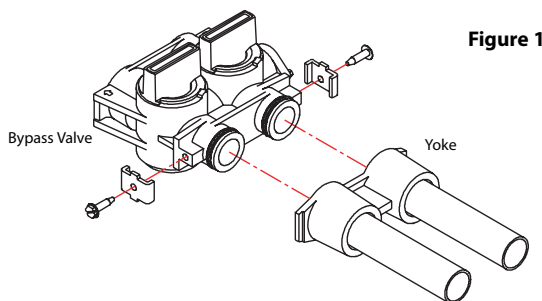

! Important Note: The bypass valve is not designed to withstand heat from soldering or twisting from the attached threaded connections.

- Support all plumbing connected to the yoke.
- Do not point the soldering torch directly at the mineral tank or control valve. These composite materials will last a lifetime, but can not withstand the intense heat from a torch.
- Avoid short connections of pipe between the system and the water heater. If you can't avoid a short connection, move the system to another location. As a last resort, install a heat trap or check valve. If this causes "water hammer", install a water hammer suppressor.
- Connect the raw water supply to the inlet pipe connection of the yoke. When looking at the front of the unit, the inlet is the pipe connection on the right side of the valve. There is an arrow molded into bypass valve indicating the direction of flow.
- Connect the treated water pipe to the outlet pipe connection on the yoke. When looking at the front of the unit, the outlet is the pipe connection on the left side of the valve. There is an arrow molded into the bypass valve indicating the direction of flow.

! Important Note: Too much weight on the plumbing connections will cause a leak.

! Important Note: Short connections of pipe may allow hot water to back up into the system.

10. Set the Bypass Valve to Bypass

- Move the bypass valve handles to the bypass position. The valve handles should be perpendicular to the pipes (see figure 2).

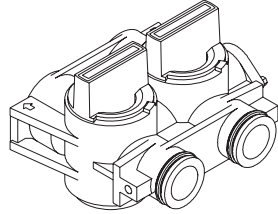

Figure 2

11. Install the Drain Line and Air Gap (Air Gap Not Supplied)

- Connect the 1/2 inch ID drain line to the drain outlet on back of the valve, opposite the inlet connection (see figure 3). A fitting is required to connect the female pipe thread to the drain line.

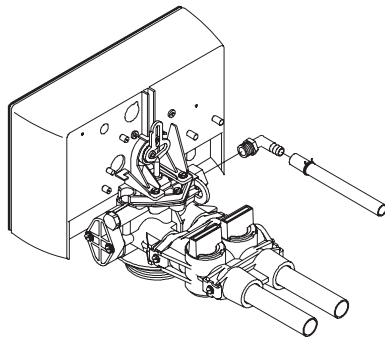
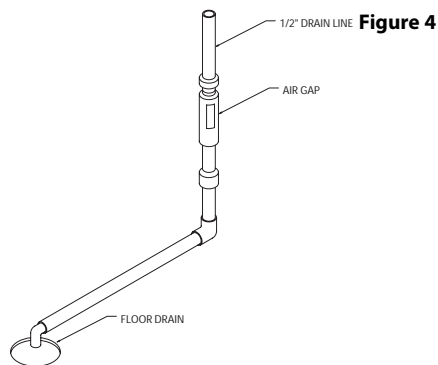

Figure 3

- Run the drain line to the air gap (see figure 4).



12. Connect the Potassium Solution Tank

- Remove the three safety screws from the lid.
- Use the tubing (supplied) to connect the potassium tank to the valve body. Use a back-up wrench on the brass fitting attached to the valve body.
- Add water to the solution tank until the water becomes visible above the mat and then add the Potassium Permanganate.
- Properly secure the solution tank lid.

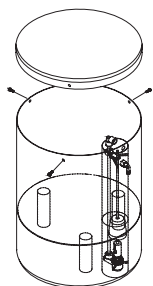

Figure 5

Helpful Tip: The drain line operates under pressure and can be installed higher than the filter.

Important Notes: The air gap should be two times the diameter of the drain line or a minimum of two inches. Please check your local plumbing codes to ensure compliance.

The air gap must be open and free of obstructions to achieve a proper backwash rate (see figure 4).

Important Note: Over-tightening the fitting may crack the valve body.

Important Notes: Over time, the matting on the Potassium shelf may become plugged or damaged. Replacement matting is available from your local RainSoft Dealer.

The solution tank will hold a maximum of fifteen pounds.

Important Notes: The solution tank must be filled with Potassium Permanganate at all times. If the Potassium Permanganate and filter media (Manganese Greensand) are completely exhausted, the system may be permanently damaged.

Potassium Permanganate is a strong caustic chemical and must be handled with care and stored safely! Nitric acid and other strong oxidizing agents can cause explosive reactions when mixed with organic materials such as ion exchange resins or potassium permanganate! Before using strong oxidizing agents, consult sources knowledgeable in handling such materials!

13. Create the Electrical Connection

- Remove the supplied wire from the warranty pack. Attach the U shaped connectors (supplied) to the wire with a crimping tool (not supplied).
- Connect the wire to the transformer. Insert the other end of the wire, with the connector, into the back of the control box (see figure 6).
- Plug the transformer into a 110 VAC 60 Hz or 230 VAC 50 Hz outlet.

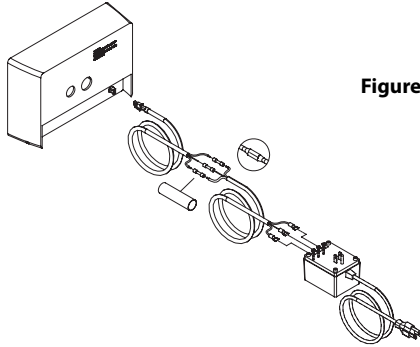

Figure 6

Helpful Tip: If the wire is too short, use the supplied connectors and shrink tubing to lengthen the wire (see figure 7).

Helpful Tip: Squeeze the connector to release it from the box.

Helpful Tip: Check the transformer label for the correct voltage requirement.

System Start Up

1. Turn on the Water and Check for Leaks

- Close all faucets and turn the water back on at the water meter or pressure tank.
- Check for leaks. If a leak is present, drain the plumbing again before soldering.

2. Flush the Remaining Debris from the System

- Open the cold water faucet on your bathtub. Allow the system to flush the remaining dirt and debris into the bathtub, until the water runs clear.
- Open all remaining faucets and allow the plumbing to release any trapped air in the system.
- Close all faucets.

Helpful Tip: This procedure will prevent dirt and debris from entering the valve.

3. Open the Bypass Valve

- Move the bypass valve handles to the service position. The valve handles should be parallel to the pipes (see figure 7).

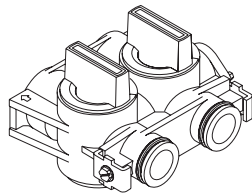

Figure 7

- Open the bathtub faucet again and allow the system to fill and flush for approximately 5 minutes.

4. Flush the Remaining Untreated Water from the Water Heater

- Run hot water in the bathtub to remove any remaining untreated water.

5. Set the Timer

- Please refer to the System Settings on pages 9-10.

Important Note: Additional flushing may be required to remove residue from the plumbing.

System Settings

Operation of the Timer

The timer is designed for years of maintenance free service, with minimal initial setup. Once the parameters are established and set by a RainSoft Representative, there is no need to adjust or change the parameters of the timer. If a noticeable change in the quality of your water has taken place, please contact your RainSoft Dealer immediately.

How to Adjust the Time of Day

To set or change the time of day, pull out and rotate the 24 Hour Time Dial until the corresponding hour on the dial is lined up with the Current Time of Day Pointer (see figure 8).

After the position of time is reached, release the 24 Hour Time Dial, ensuring that the dial reseats in gear.

How to Adjust the Time of Regeneration

To set or change the time of regeneration, pull out and rotate the Time of Regeneration Pointer until the desired time of regeneration is viewable in Regeneration Hour View Window (see figure 8).

Release the Time of Regeneration Pointer, ensuring that the pointer seats properly on the 24 Hour Time Dial.

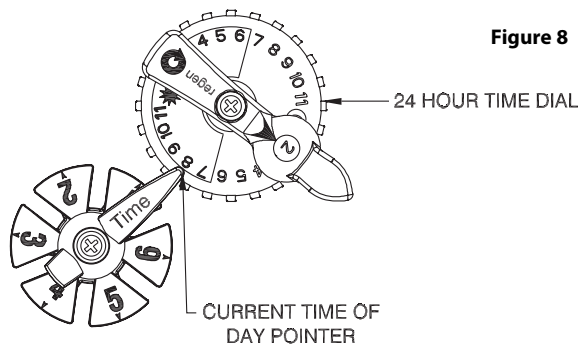

Figure 8

How to Adjust the Backwash Time

The recommended backwash time for most applications is 10–15 minutes. To set or change the backwash time, hold the Backwash Indicator Lever and rotate the Backwash/Rinse Dial to the desired backwash time (see figure 9). The Backwash Indicator Lever will lock itself into the new position.

How to Adjust the Fast Rinse Time

The factory setting is 8 minutes, which is adequate for most applications. If you choose to adjust the fast rinse time, hold the Backwash/Rinse Dial and move the Rinse Pointer with a pen or leverage device to the desired fast rinse time (see figure 9). The Rinse Pointer will lock itself into the new position.

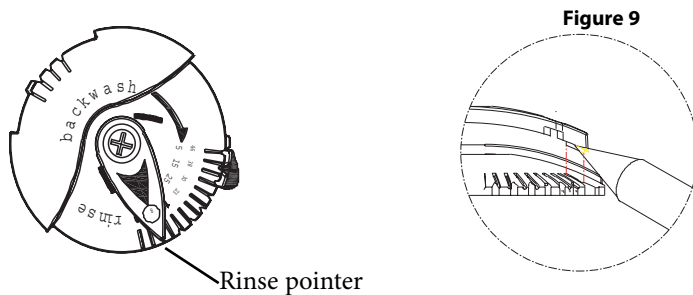

Figure 9

Helpful Tips: The nighttime period is the half colored black with a moon. The daytime period is depicted by the light colored half with a sun.

If you change from standard to daylight savings time, you may want to reset the time of day. If the power goes out, you must reset the time of day.

Important Note: If you have more than one system, do not set the regenerations for the same time of day. We recommend setting the regenerations at least two hours apart.

Important Notes: When adjusting this function, it is recommended that the power be disconnected.

Important Note: When adjusting this function, it is recommended that the power be disconnected.

How to Adjust the Frequency of Regenerations

The recommended regeneration schedule for most applications is every day or every other day in cases of low iron and/or minimal water use. The days of regeneration are based on a 6 day timing scheme. A pressed numbered pin will correspond to an automatic regeneration when that particular day is reached.

To set or change the frequency of regenerations, simply press in the corresponding day pin to initiate an automatic regeneration on that day (see figure 10).

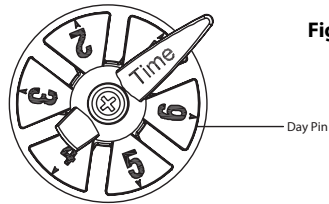

Figure 10

Example: If your water consumption dictates a regeneration every 3 days, simply press in the number 1 and 4 pin.

How to Manually Initiate a Regeneration

If you foresee using a large quantity of water, a manual regeneration is often recommended. To manually initiate a regeneration, press the Manual Regeneration Button (see figure 11).

How to Cancel a Manual Regeneration

To cancel a manual regeneration that is already in progress, simply rotate the Backwash/Rinse Dial until the Rinse Pointer is in the middle of the Reset section on the timer faceplate (see figure 11).

When the timer has been reset, the regeneration will be cancelled and the timer will return to the service position.

! Important Note: Cancelling a regeneration that is already in progress may stop the filter from properly cleaning.

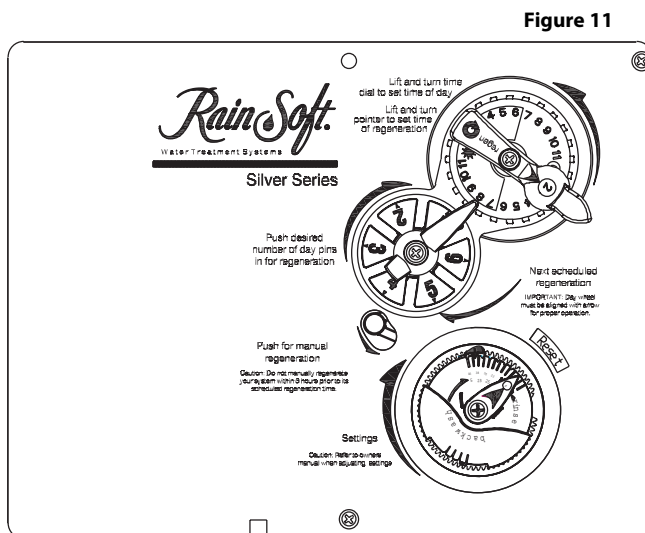

Figure 11

TROUBLESHOOTING YOUR UNIT

SYMPTOM	CAUSE	SOLUTION
1. The system fails to regenerate automatically	<ol style="list-style-type: none"> 1. The power supply is plugged into an intermittent or dead power source. 2. The proper amount of day pins are not depressed. 	<ol style="list-style-type: none"> 1. Connect to a constant power source. 2. Depress the proper amount of pins.
2. The system regenerates at the wrong time	<ol style="list-style-type: none"> 1. The timer is not set properly. 2. The time is off due to daylight savings. 	<ol style="list-style-type: none"> 1. Reset the time of day and hour of regeneration. 2. Reset the time of day.
3. The system becomes exhausted before the next regeneration	<ol style="list-style-type: none"> 1. The amount of iron or Manganese has increased in the water supply. 2. The potassium tank is empty. 3. Increase in water use. 	<ol style="list-style-type: none"> 1. Call your RainSoft Dealer for a new water analysis. 2. Add potassium to the tank. 3. Manually regenerate the system.
4. Rusty water or water that smells like sulfur	<ol style="list-style-type: none"> 1. The bypass valve is partially open. 2. No power to the system. 3. The system is not regenerating often enough. 4. Only the hot water is rusty. 	<ol style="list-style-type: none"> 1. Close or repair the bypass valve. 2. Check the power supply. 3. Recalculate the regeneration schedule. 4. Drain and flush the hot water heater. Replace if necessary.
5. High Potassium Permanganate use	<ol style="list-style-type: none"> 1. Improper timer set-up. 2. Excessive water in the solution tank. 	<ol style="list-style-type: none"> 1. Call your RainSoft Dealer to reset the timer. 2. See Symptom #7.
6. Loss of water pressure	<ol style="list-style-type: none"> 1. Low water pressure to the system. 	<ol style="list-style-type: none"> 1. Bypass the system and call your RainSoft Dealer for service.
7. Excessive fluid in the Potassium tank	<ol style="list-style-type: none"> 1. The float assembly is not operating properly. 2. Air leak on the connection to the Potassium tank. 	<ol style="list-style-type: none"> 1. Clean or replace the float assembly. It is recommended that the float assembly be serviced annually. 2. Check all the connections. Replace if necessary.
8. The system fails to consume Potassium	<ol style="list-style-type: none"> 1. No water in the solution tank. 2. The water pressure is too low. 	<ol style="list-style-type: none"> 1. Contact your RainSoft Dealer for service. 2. Contact your RainSoft Dealer for service.
9. The system cycles continuously	<ol style="list-style-type: none"> 1. Timer motor or switch failure. 	<ol style="list-style-type: none"> 1. Call your RainSoft Dealer for service.
10. Constant water flow to the drain	<ol style="list-style-type: none"> 1. Foreign material in the valve. 2. The timer mechanism is stuck. 	<ol style="list-style-type: none"> 1. Call your RainSoft Dealer to clean the valve. 2. Call your RainSoft Dealer for service.

If the troubleshooting section did not resolve the unit's symptoms, please contact your local RainSoft Dealer for service. If you cannot locate your local RainSoft Dealer, please contact RainSoft Customer Service at 1-800-860-7638 or log onto www.rainsoft.com for the name and location of your nearest Dealer.

Valve Exploded View and Parts List

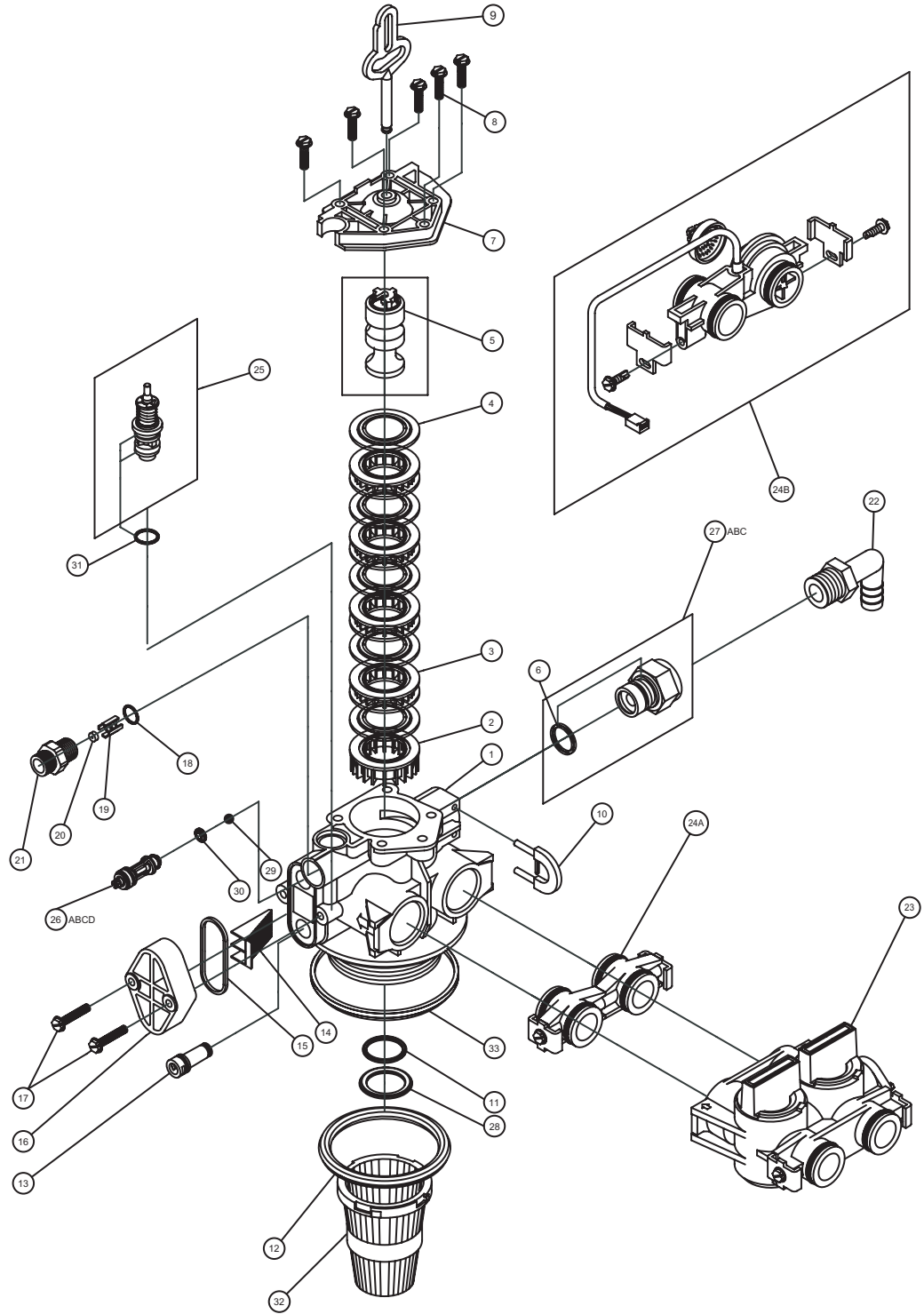

Valve Exploded View and Parts List

ITEM	PART NUMBER	DESCRIPTION	QUANTITY
1	17863	VALVE	1
2	17864	SPACER END	1
3	17865	SPACER (INTERNAL)	4
4	17866	SEAL (INTERNAL)	5
5	18160	PISTON AND RETAINER	1
6	10258	O-RING -017	1
7	17869	END PLUG ASSEMBLY	1
8	17870	10-24 X .812 SCREW	5
9	17871	PISTON ROD	1
10	17887	DRAIN RETAINER	1
11	17888	O-RING -121	1
12	17889	O-RING -336	1
13	17617	INJECTOR PLUG ASSEMBLY	1
14	17948	INJECTOR SCREEN	1
15	17949	INJECTOR SEAL	1
16	17950	INJECTOR CAP	1
17	17951	10-24 X 1.0 SCREW	2
18	17958	O-RING -015	1
19	17953	RETAINER BLFC BUTTON	1
20	17954	FLOW CONTROL WASHER 0.25 GPM	1
21	17957	BLFC ADAPTER 0.25 GPM	1
22	17939	ELBOW BARB 1/2 X 1/2 NPT	1
23	17557	BYPASS VALVE	1
24A	17560	ADAPTER COUPLING ASSY 3/4	1
24B	17558	METER TURBINE ASSY	1
25	17812	REFILL SHUTOFF ASSEMBLY	1
26A	17947	INJECTOR #0 ASSEMBLY	1
26B	18194	INJECTOR #1 ASSEMBLY	
26C*	19318	INJECTOR #2 ASSEMBLY	
26D	19393	INJECTOR #3 ASSEMBLY	
27A	17994	DRAIN LINE FLOW CONTROL 3.0	1
27B*	18267	DRAIN LINE FLOW CONTROL 6.0	
27C	18287	DRAIN LINE FLOW CONTROL 5.0	
28	18445	RISER PIPE O-RING RETAINER	1
29	18857	CHECK BALL INJECTOR	1
30	18855	INJECTOR SEAT ASSEMBLY	1
31	13329	O-RING -014	2
32	17941	RED UPPER BASKET 1 X .008	1
33	19328	SEAL TANK RETAINER	1

Control Exploded View and Parts List

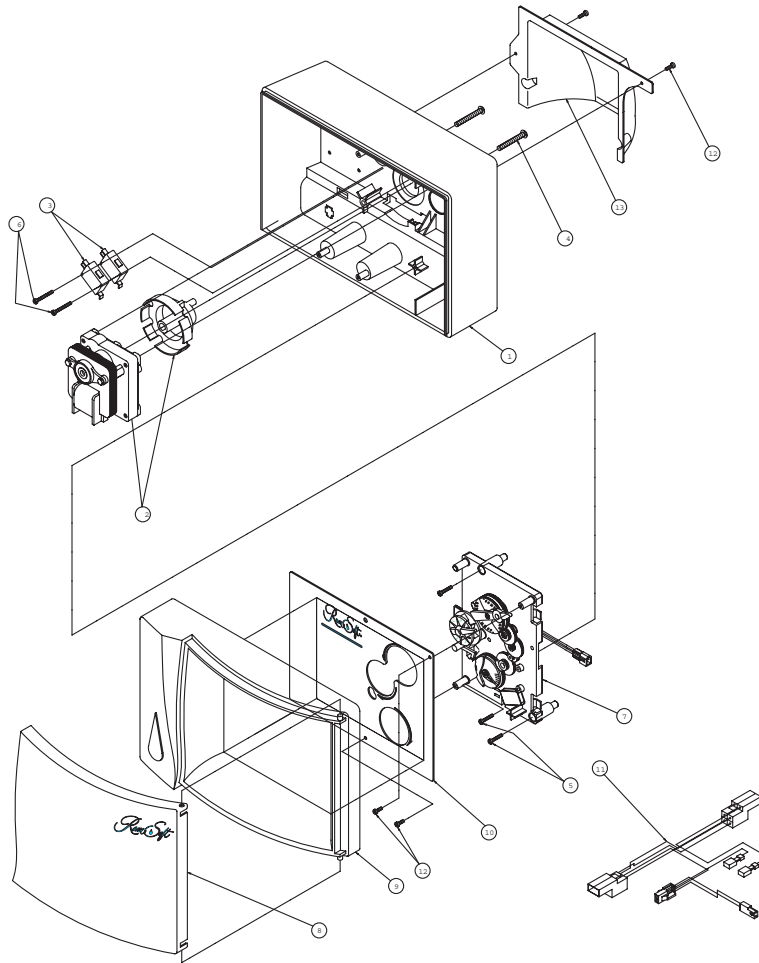

Item	Quantity	Part Number	Description
1	1	17487	REAR HOUSING
2	1	18619	24V 50/60 HZ VALVE MOTOR WITH FILTER CAM
		18620	DRIVE MOTOR
		18278	DOWN FLOW GEAR/CAM FILTER
3	1	19029	45 ° SWITCH ACTUATOR SILVER CONTACT
4	2	17548	10-32 X 1.50 SCREW PAN HEAD PHIL MACH SS
5	3	17544	4-20 X .625 SCREW PAN HEAD PHIL SS
6	2	18135	4 X 1.25 SCREW SLOTTED HEX WASHER TYPE 25
7	1	18251	TIMER PLATE, 6 DAY FILTER ASSEMBLY 24V 60 HZ
		18252	TIMER PLATE, 6 DAY FILTER ASSEMBLY 24V 50 HZ
8	1	17489	FRONT HOUSING DOOR, SILVER
9	1	17854	FRONT HOUSING, SILVER
10	1	17495	MECHANICAL TIMER COVER PLATE
11	1	17553	MECHANICAL WIRE HARNESS
12	4	17542	4-20 X .375 SCREW PAN HEAD PHIL SS
13	1	17490	REAR HOUSING COVER

TIMER EXPLODED VIEW AND PARTS LIST

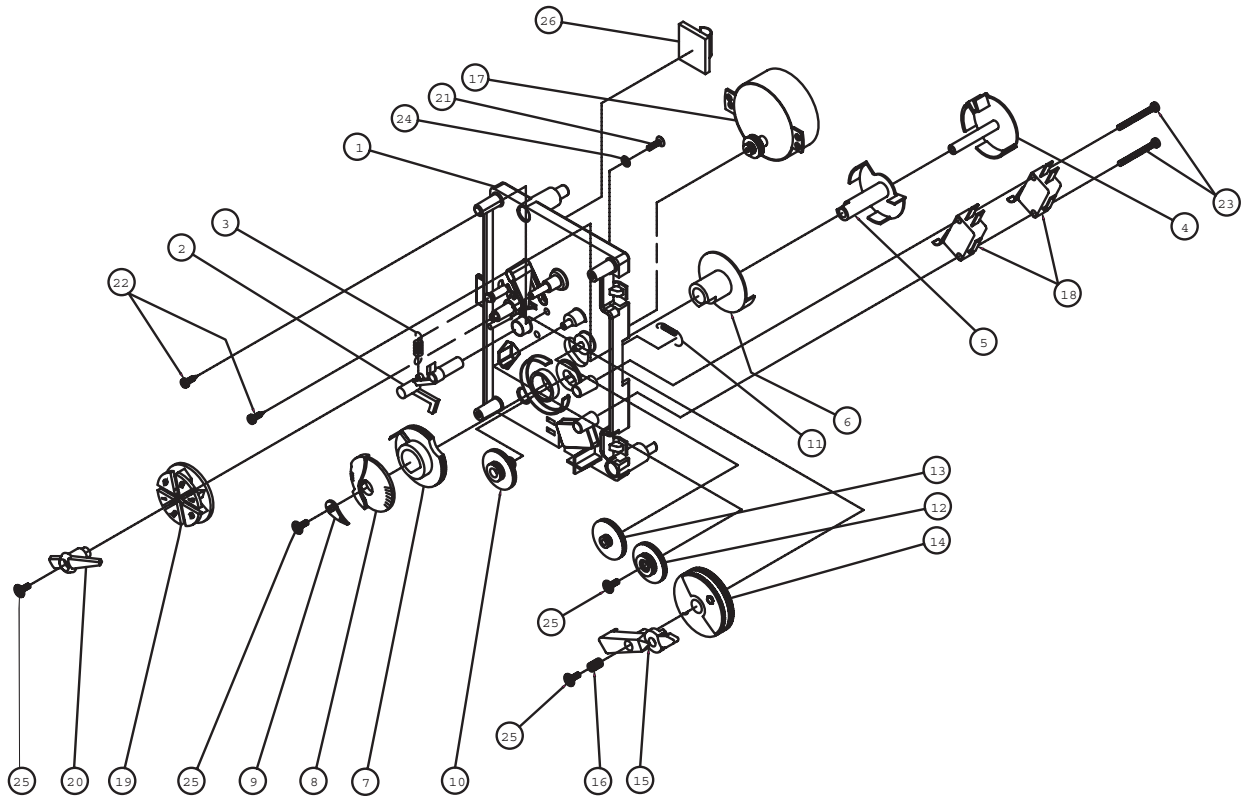

ITEM	PART NUMBER	DESCRIPTION	QUANTITY
1	17491	TIMER BASE PLATE	1
2	17512	REGEN ACTUATOR ARM	1
3	17524	REGEN ACTUATOR ARM SPRING	1
4	18994	REFILL CAM ASSEMBLY	1
5	17614	BACKWASH CAM	1
6	17613	BASE CAM	1
7	17505	SALT/BACKWASH GEAR	1
8	18939	CYCLE DIAL	1
9	17500	SALT DOSE POINTER	1
10	17506	TIMER GEAR #4	1
11	17525	TIMER GEAR #4 SPRING	1
12	17509	TIMER GEAR #1	1
13	17508	TIMER GEAR #2	1
14	17510	24 TIME DIAL	1
15	17513	REGEN TIME POINTER	1
16	17523	REGEN TIME POINTER SPRING	1
17	17493	TIMER MOTOR 24V 60 HZ 1/30 RPM	1
18	17977	RADIAL ACTUATOR SWITCH	2
19	17845	6 DAY SELECTOR DIAL ASSEMBLY	1
20	17511	CURRENT TIME POINTER	1
21	17542	4-20 X 3/8 SCREW	1
22	18238	6-32 X 3/8 SCREW	2
23	18135	4-20 X 1-1/4 WASHER	2
24	18265	#4 WASHER	1
25	18899	2-24 X 3/8 WASHER	4
26	19123	ADHESIVE CABLE CLAMP	1

SOLUTION TANK EXPLODED VIEW AND PARTS LIST

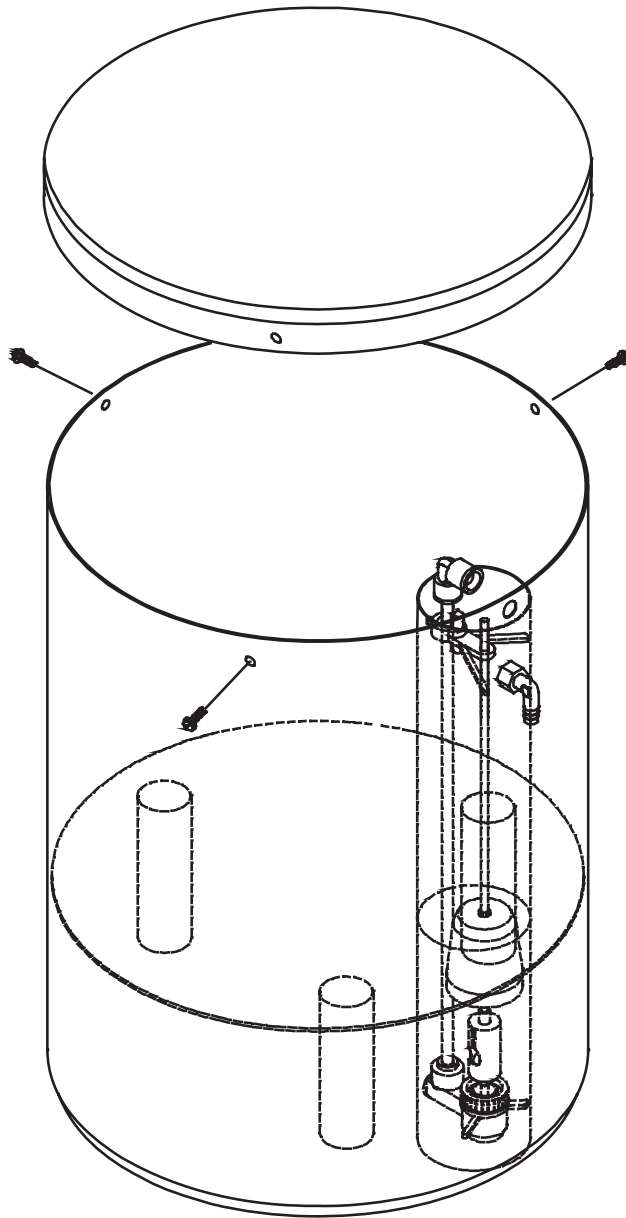

ITEM	PART NUMBER	DESCRIPTION	QUANTITY
1	N/A	SOLUTION TANK	1
2	19049	FLOAT VALVE	1
3	19046	DRAIN ELBOW	1
4	N/A	GRID	1
5	19150	FOAM PAD	1
6	19149	TANK LID	1
7	N/A	SCREW	3
8	N/A	3/8" TUBE	1

MINERAL TANK EXPLODED VIEW AND PARTS LIST

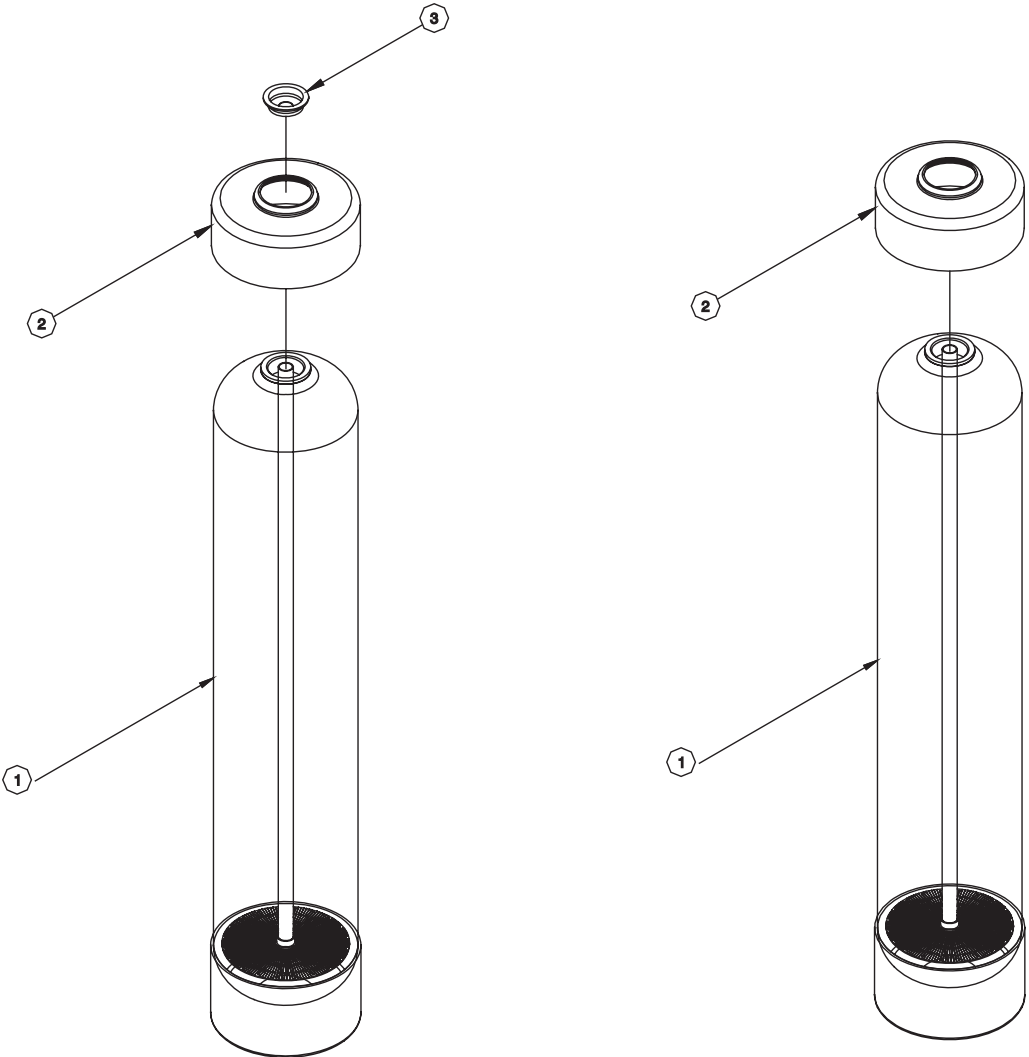

F8C 100 GP

ITEM	PART NUMBER	DESCRIPTION	QUANTITY
1	51324	10 X 44 GRAY TANK WITH INTEGRATED DISTRIBUTOR	1
2	18659	10" TANK COLLAR	1
3	17968	TANK CAP W/RISER PIPE HOLE	1

F8C 150 GP

ITEM	PART NUMBER	DESCRIPTION	QUANTITY
1	51327	10 X 54 GRAY TANK WITH INTEGRATED DISTRIBUTOR	1
2	18659	10" TANK COLLAR	1

Limited Lifetime Warranty

For as long as you own the equipment

RainSoft Division of Aquion Water Treatment Products, believing its

F8C WATER FILTRATION SYSTEM

to be of exceptional quality, hereby warrants said equipment to its first purchaser at retail as follows:

THE TREATMENT TANK AND VALVE ARE WARRANTED AGAINST DEFECTS IN MANUFACTURE FOR THE LIFETIME OF THE FIRST PURCHASER AT RETAIL.

THE ELECTRICAL PARTS ARE WARRANTED AGAINST DEFECTS IN MANUFACTURE FOR FIVE YEARS AND PRO-RATA WARRANTED FOR AN ADDITIONAL FIVE YEARS.

THE COMPONENTS OF THE SOLUTION TANK ARE WARRANTED FOR ONE YEAR

THE FILTER MEDIA IS NOT WARRANTED. THE FILTER MEDIA SERVICE LIFE IS DEPENDENT ON SPECIFIC WATER CONDITIONS AND USAGE.

This warranty begins at the time the equipment is first connected for use, and is contingent upon the return of a signed owner's registration card.

This warranty does not require replacement of the entire unit. If the equipment does not perform properly, you should request service from the dealer that sold you the equipment. If you are not satisfied, you should notify our Customer Service Manager. If we are not able to arrange local servicing, you should send the defective part(s) (or, if you prefer, send the entire unit,) directly to the manufacturer, freight prepaid, with proof of purchase and a copy of this warranty. The defective part(s) (or entire unit) will either be repaired or new RainSoft part(s) furnished, for a nominal charge to cover labor, handling, packing and the increase, if any, in the retail price of the part(s) since the date of purchase. Genuine RainSoft parts must be used. Failure to use genuine RainSoft parts will void the warranty and certifications.

This warranty does not include labor charges, and does not cover installation, transportation, or any other claims or torts. Some states do not allow the exclusion or limitation of incidental or consequential damages, so parts of the above limitation or exclusion may not apply to you.

This warranty gives you specific legal rights, and you may also have other rights which vary from state to state. You also have implied warranty rights. In the event of a problem with warranty service or performance, you may be able to go to a small claims court, a State court, or a Federal District Court.

This warranty is void if equipment is not installed and operated according to instructions. It does not apply to damage caused by abuse, accident, neglect, freezing, fire, or other abnormal conditions beyond the company's control. This warranty is void on any part from which the manufacturing date has been removed or made illegible.

Benefits will be provided by various types of RainSoft equipment when installed and operated according to the manufacturer's recommendations. Operational, maintenance and replacement requirements are essential for the product to perform as advertised. All claims are based on the best available information at the time of printing. Manufacturer makes no representations as to the suitability of this equipment for a particular application. Buyer relies entirely on the dealer's recommendations in the purchase of this equipment.

Independent RainSoft dealers may include, together with your RainSoft product, a product or component that is not manufactured by RainSoft or their parent company, AWTP, LLC. Any non-RainSoft product may be covered by the manufacturer of that product, and is not covered by the RainSoft warranty. AWTP, LLC does not warrant that your RainSoft product and the non-RainSoft product will perform properly when used together, and assume no liability therefore.

RainSoft Division of Aquion Water Treatment Products
2080 East Lunt Avenue
Elk Grove Village, Illinois 60007 USA

Installer Specification Sheet

Dealer Name: _____

Phone Number: _____

Installation Number: _____

Installation Date: _____

Model Number: _____

Serial Number (See label): _____

Line Pressure: _____ (psi)

Iron: _____ Hardness: _____

pH: _____

Sulfur: _____

Backwash Flow Rate: _____ (gpm)

Recommended Regeneration Frequency: (Circle) 1 2 3 4 5 6 7 Days _____

Recommended Backwash Time: _____ (10 minutes minimum)



RainSoft Division of Aquion Water Treatment Products
2080 East Lunt Avenue
Elk Grove Village, Illinois 60007
Main Switchboard: 1.847.437.9400
Customer Service: 1.800.860.7638
www.rainsoft.com